



## THE QUIET ONE™

## Blending Station® Advance™

### Up to 4 Times Quieter Than the Competition

Innovative vibration dampening technology creates Vitamix quality drinks in a more enjoyable customer atmosphere.

### Magnetically Secured Floating Sound Enclosure

Dramatically easier to clean and disassemble. No screws to damage the enclosure. No parts to lose.

### Ultimate Blending Flexibility and Optimization

Variable speed control and automatic shut-off provide flexibility in creating endless recipes.

The 6 program buttons with 34 optimized programs in memory provide operators with easy, consistent drinks every time.

Custom blending programs can easily be created for signature drinks.

### Improved Speed of Service

The Advance™ container design reduces blend and pour time for faster customer service.

### Designed for High Performance

Air management and powerful  $\approx 3$  peak (output) HP motor reduces noise, improves reliability and reduces down time.



## Product Specifications

### The Quiet One™

On-Counter: # 36019 / In-Counter: # 40009

Motor: ≈ 3 peak (output) motor horsepower

Electrical: 120 V, 50/60 Hz, 15 amps

Pack: Includes The Quiet One Blending Station Advance with 48 oz. / 1,4 L high-impact, clear/stackable Advance™ container complete with blade assembly and lid, compact enclosure\*

Net Weight: 20.0 lbs., (28.0 lbs. with box)

#### Dimensions:

On-Counter: Height with lid closed: 18.0 in. / 45,72 cm  
 Height with lid open: 26.75 in. / 67,95 cm  
 Depth with handle: 9.8 in. / 24,89 cm  
 Width: 8.8 in. / 22,35 cm

In-Counter: Height with lid closed: 16.8 in. / 42,67 cm  
 Height with lid open: 22.8 in. / 57,9 cm  
 Depth with handle: 9.8 in. / 24,89 cm  
 Depth below counter: 3.0 in. / 7,62 cm  
 Width: 8.8 in. / 22,35 cm

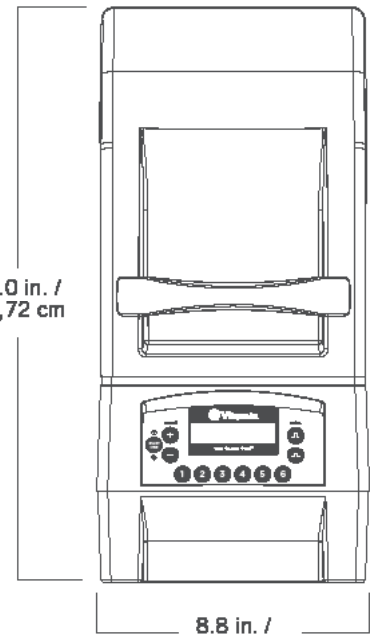

18.0 in. /  
45,72 cm

8.8 in. /  
22,35 cm

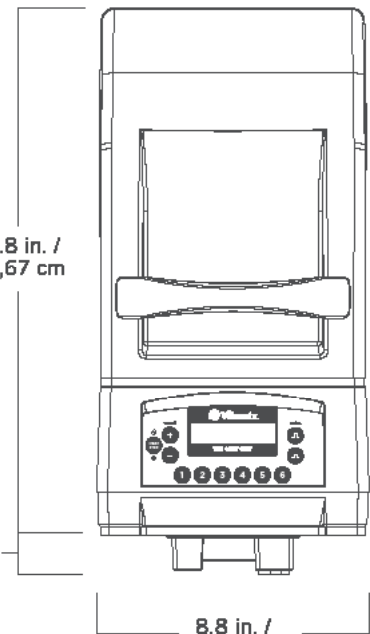

16.8 in. /  
42,67 cm

3.0 in. /  
7,62 cm

8.8 in. /  
22,35 cm



Assembled in the U.S.A. of U.S.A. and Swedish components.  
 FOR COMMERCIAL USE ONLY.

Warranty: The Quiet One is backed by a three year warranty on motor base parts and a one year warranty on labor. For more information regarding this warranty please contact your local distributor, dealer, or Vitamix direct.

\* Compact enclosure may be used with the XP container only when used with one-piece splash lid.

## Also Available

Advance™ Container: 15978

48 oz. / 1,4 L container complete with blade assembly and lid.



## Contact Information

Vita-Mix Corporation  
 8615 Usher Road  
 Cleveland, OH 44138-2103  
 U.S.A.

U.S.A., Canada & Latin America:  
 Tel: 800.4DRINK4 or  
 440.235.0214  
 E-mail: [foodservice@vitamix.com](mailto:foodservice@vitamix.com)

Outside of the U.S.A., Canada &  
 Latin Amrica:  
 Tel: +1.440.782.2450  
 E-mail: [international@vitamix.com](mailto:international@vitamix.com)